

1 GENERAL

- 1.1 All documents must be used in conjunction with the latest revision of Lakeland Power Distribution Ltd. ('LPDL') Conditions of Service as posted on www.lakelandpower.on.ca.
- 1.2 The demarcation point shall be specified on the offer to connect layout per Lakeland Power's latest conditions of service.
- 1.3 All service entrance equipment (mast, meter base, load wiring, etc.) is the responsibility of the customer and must meet the requirements of the Ontario Electrical Safety Code ("OESC"). LPDL will not make any connections or reconnections prior to receiving a Connection Authorization from the Electrical Safety Authority ("ESA").
- 1.4 LPDL will specify the meter location and point of supply for the service. There is only one point of supply allowed per individual dwelling per Lakeland Power's latest Conditions of Service.
- 1.5 LPDL will supply a single phase service, rated at 120/240 volts, to a maximum of 400 amps per Lakeland Power's Conditions of Service.
- 1.6 Temporary services are approved for connection up to 6 months. Service connection can be extended at the discretion of Lakeland Power pending a connection extension request from the customer and submission of an ESA inspection.

2 REQUESTING SERVICE

- 2.1 Determine the scope of work in detail.
- 2.2 Complete a Service Request form to schedule a technician's review of the proposed request.
- 2.3 Receive an Offer to Connect Layout that specifies LPDL requirements and charges.
- 2.4 Make applicable payments to Lakeland Power Distribution Ltd. by money order or cash or cheque at our Bracebridge or Huntsville office.
- 2.5 Call the LPDL Engineering Technician/Technologist that issued the offer to connect layout at 705-645-2670 to schedule the work.

3 SERVICE LAYOUT CONDITIONS

- 3.1 Drawings are not to scale. Property lines, utilities, structures, roads, driveways, and other terrain is not necessarily shown. The accuracy of details shown is not guaranteed.
- 3.2 Additional charges will apply above estimate for work not anticipated.
- 3.3 Customer is responsible for all required surveys, easements, permits, or other requirements from all parties.
- 3.4 Work may be subject to approval from the applicable road authority.

- 3.5 Work may be subject to change based on requirements of other affected parties such as communications companies or other utility owners.
- 3.6 Customer is responsible for ensuring work area is accessible and clear of all vehicles, snow, fill, debris or other obstructions.
- 3.7 Payment in full required prior to commencement of work.
- 3.8 Service layout is valid for 6 months from the time received by the customer.
- 3.9 Equipment and/or transformers to be ordered upon project approval and payment in full by the customer. Delivery times are subject to any supply chain issues and are, at times, expected to be greater than 18 months.

4 METER BASE REQUIREMENTS

- 4.1 The revenue meter is the property of LPDL and must be easily accessible by LPDL. If, in the opinion of LPDL, obstructions such as A/C units, gas meters, window wells, trees, bushes, etc., render the meter inaccessible, the meter must be relocated to a LPDL approved location at the customer's expense, or, the obstruction be removed or relocated 1m away from the meter.
- 4.2 Existing meter bases must be replaced if i) they do not pass ESA inspection; ii) measure 8"x8" or less; iii) is an A-Base style iii) are located inside; and/or iv) fail during disconnect/reconnect of the meter. LPDL may require other service entrance equipment to be replaced for safety and/or reliability reasons.
- 4.3 The center of the meter must be 1.73m±100mm above finished grade.
- 4.4 Meter base shall be located a minimum of 3.0m from propane gas regulator vent and 1m from natural gas regulator vent.
- 4.5 Line side and load side connections are to be completed in the meter base prior to LPDL arriving on site.
- 4.6 **400A Meter Bases:** To be Microelectric JS4 series or equivalent. CT to be supplied and installed by LPDL at time of service connection, at customers expense.
- 4.7 **Service Identification:** Permanently and legibly identify all metered services with respect to correct municipal civic address and unit number. Assigned unit numbers must correspond with the Offer to Connect Layout and ESA's Connection Authorization.

5 OVERHEAD REQUIREMENTS

- 5.1 All trees and woody growth adjacent to a line shall be trimmed so that minimum clearance to the nearest conductor horizontally at maximum conductor swing and vertically at a maximum sag shall meet LPDL's latest Tree Trimming Specifications available on the website or OESC for privately-owned lines.

- 5.2 Residential customer's service mast, first service pole, or downpipe, must be located within 38m of connection point indicated in the offer to connect layout.
- 5.3 All customer owned pole lines to be supplied and installed by the customer as per OESC. Primary and neutral conductors to be coiled at first customer pole for connection to LPDL pole line by LPDL unless otherwise specified in the offer to connect layout.
- 5.4 LPDL will make the final connections at the customer's service mast.

6 UNDERGROUND REQUIREMENTS

6.1 General Requirements:

- 6.1.1 All cable runs must be complete with a heat or cold shrink cap immediately after cutting.
- 6.1.2 All duct and cable to be installed per table below unless subject to additional requirements by the road authority.

Trench and Cable Depths		
Cable Type	Cable Depth	Trench Depth
Primary	900mm (36")	1050mm (42")
Secondary	750mm (30")	900mm (36")

Refer to Figure 4.

- 6.1.3 Where depth cannot be achieved, cables must be encased in concrete per LPDL specification. Refer to standard Figure 1 for concrete encasement specs.
- 6.1.4 All underground cables are to be installed in either i) 100mm Type DB2/ES2 PVC duct or, ii) smooth-wall SDR-13.5 HDPE duct.
- 6.1.5 All duct to be installed with 150mm of grit-free masonry mortar sand above and below the conduit.
- 6.1.6 Supply and install Buried Cable Warning Tape at 8" below finished grade spanning full length of trench.
- 6.1.7 Route of all cables to be approved by Lakeland Power.
- 6.1.8 All 90 degree bends in conduit to be a minimum 1m radius.
- 6.1.9 **Locates:** All utilities (water, sewer, hydro, telephone, cable TV, etc) must be contacted prior to excavation. Contact Ontario One Call at 1-800-400-2255 or visit <https://ontarioonecall.ca/> to request locates for all underground utilities.
- 6.1.10 LPDL to be on-site to supervise all excavation within 2m of transformer, switchgear, junction cubical and splice vaults.
- 6.1.11 **Inspection:** Coordinate with LPDL for trench, vault, ground grid inspection. All inspections require a minimum of 48 hours notice. Duct banks to be inspected prior to being backfilled or concrete encased.
- 6.1.12 Customer to restore all existing finishes to like condition or better.

- 6.1.13 Cable and conduit shall not be installed below -10C temperature because of high risk of duct damage and/or coupling separation.

6.2 LPDL-Owned Primary Cable:

- 6.2.1 Installations must meet all requirements in section 6.1.
- 6.2.2 Supply and install primary cable; 28KV 2/0 Alum TR-XLPE PEEJ primary underground cable with 100% concentric.
- 6.2.3 Cable to be installed in approved duct (See section 6.1.4) as per routing shown on offer to connect layout. Supply and install spare duct complete with 1/4" poly rope and capped at both ends.
- 6.2.4 Duct to end at the pole as per Figure 2.

6.3 LPDL-Owned Secondary Cable:

- 6.3.1 Installations must meet all requirements in section 6.1.
- 6.3.2 Customer to supply and install 3/0 USEi90 secondary cable up to 60m in length or 250MCM up to 90m in length.
- 6.3.3 Cable to be installed in approved duct (See section 6.1.4) from the meter base downpipe to the point of supply.
- 6.3.4 Secondary cable duct ends at pole to be installed as per Figure 2.
- 6.3.5 Secondary cable duct ends at meter base to be installed as per Figure 3.

6.4 Customer-Owned Primary Cable:

- 6.4.1 Supply and install all primary cable per Ontario Electrical Safety Code.
- 6.4.2 Cable to be 28KV 2/0 Alum primary underground cable with 100% concentric.

6.5 Customer-Owned Secondary Cable:

- 6.5.1 Supply and install secondary cable per OESC.
- 6.5.2 LPDL will not take ownership of ACWU cable.
- 6.5.3 For AWCU cable, provide a PVC weather head, 1 length of conduit and a minimum of 10 metal saddle clips per run of cable for installation on pole.
- 6.5.4 Maximum conductor size is 500MCM and the customer is to inform LPDL in writing as to the size, type and number of service conductors. LPDL will supply and install connections between the riser 'tail' and transformer or bus.

6.6 Cable Coils:

- 6.6.1 A minimum of 15' of each run of primary and secondary cable must be left coiled in the vault.
- 6.6.2 Secondary cable to be coiled a minimum of 35' at the base of pole for connection, unless otherwise specified in the service layout.
- 6.6.3 Primary cable to be coiled a minimum of 45' at the base of pole for connection, unless otherwise specified in the service layout.
- 6.6.4 Cables to be trenched to a location at the pole that does not interfere with existing equipment or attachments.

6.7 LPDL-Owned Transformers - Vaults:

- 6.7.1 Supply and install BCP110PC vault and ground grid for transformer. Vaults must be within 10ft of a near-level road or driveway (min 15ft wide) and be accessible by bucket and/or digger truck at all times. Exact location to be approved by Lakeland Power.
- 6.7.2 Vaults must be level. Any knockouts not used are to be securely plugged.
- 6.7.3 Install ground grid for transformer. Refer to supplied standard Figure 5.
- 6.7.4 All duct ends shall be fitted through the knockouts and end inside the vault. Lakeland Power to assist with cable pulls where required.
- 6.7.5 Vault and ground grid installation subject to Lakeland Power inspection. Backfill before inspection may require re-excavation.
- 6.7.6 Bollards may be required at the discretion of LPDL. Refer to Figure 6.

6.8 Customer-Owned Transformers Vaults:

- 6.8.1 Supply and install vault for transformer per Ontario Electrical Safety Code. Size BCP-110PC or equivalent.
- 6.8.2 Vault must be within 10ft of a near-level road or driveway and be accessible by bucket and/or digger truck at all times. Exact location to be approved by Lakeland Power.
- 6.8.3 Install ground grid for transformer for transformer per OESC.

FIGURE 1 ARRANGEMENT FOR 1-4 DUCTS ENCASED IN CONCRETE

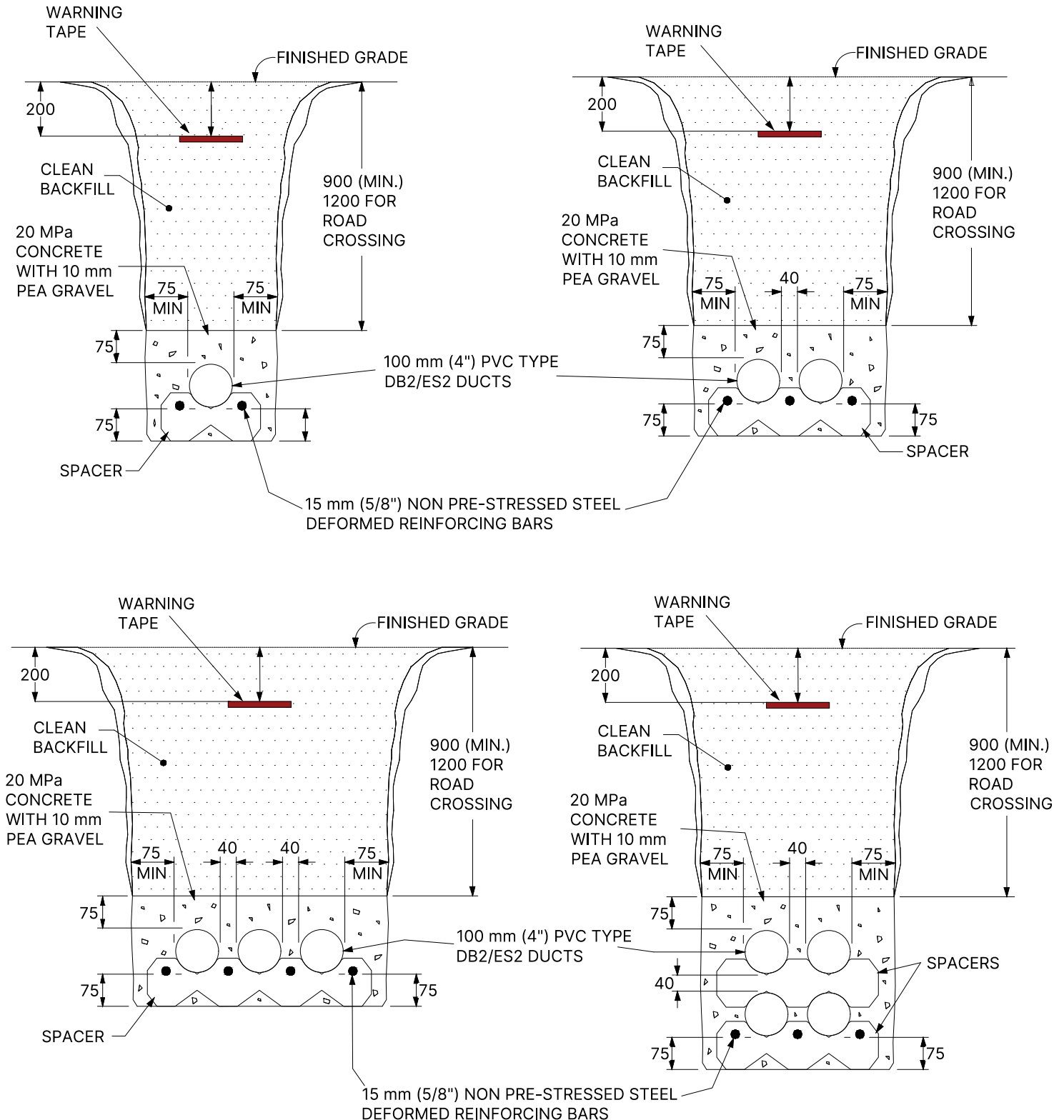

* ALL UNITS OF MEASUREMENT ARE IN MILLIMETERS UNLESS OTHERWISE STATED

FIGURE 1A

REQUIREMENTS FOR 1-4 DUCTS ENCASED IN CONCRETE

1. DESIGN CONSIDERATIONS

- 1.1. BENDS AND TURNS IN A DUCT RUN SHALL BE ACCOMPLISHED BY A GRADUAL SWEEP. ALL 90 DEGREE CHANGES IN DIRECTION SHALL BE MADE OF 1000mm RADIUS ELBOW AND BE LIMITED TO TWO PER RUN
- 1.2. DUCT BANKS SHALL BE BURIED WITH A MINIMUM COVER OF 900 mm, WITH THE EXCEPTION OF ROAD CROSSINGS WHICH SHALL BE BURIED WITH A MINIMUM COVER OF 1200 mm.
- 1.3. TRENCH RESTORATION SHALL BE MADE UP OF CLEAN BACKFILL ON DUCT BANKS INSTALLED UNDER LAWNS AND PARKWAYS. DUCT BANKS ALONG BOULEVARDS OR ACROSS ROADS SHALL HAVE BACKFILL MATERIALS AND TRENCH RESTORATION TO CONFORM WITH THE MUNICIPAL OR REGIONAL AUTHORITY, AS REQUIRED.
- 1.4. CUSTOMER'S DUCT BANK SHALL HAVE A MINIMUM SLOPE OF 1% AWAY FROM THE BUILDING. CONSULT DISTRIBUTOR'S INSPECTOR WHERE THE ABOVE REQUIREMENT CANNOT BE MET (ie. FRENCH DRAIN REQUIRED).
- 1.5. THE AREA WITHIN TWO METRES AT EACH END OF A DUCT BANK SHALL BE FREE OF ANY FOREIGN OBJECTS SUCH AS CABLES OR PIPES, FOR BACKHOE DIGGING.
- 1.6. DUCT BANK SHALL BE TERMINATED IN A LANDSCAPED AREA AT THE LOCATION GIVEN BY THE DISTRIBUTOR.
- 1.7. CONFIGURATIONS NOT COVERED TO STANDARDS SHALL BE ARRANGED IN A SIMILAR MANNER SUBJECT TO DISTRIBUTOR'S APPROVAL.

2. DUCT BANK CONSTRUCTION

- 2.1. THE DUCT SHALL BE 100 mm (4") DIAMETER, PVC TYPE DB2/ES2 (SOLID WALL ONLY) C/W BELL END AND BE APPROVED AS PER CSA STANDARD C22.2 No. 211.1 (LATEST REVISION) AND THE DISTRIBUTOR.
- 2.2. ALL FITTINGS AND BENDS SHALL BE PVC TYPE DB2/ES2. APPROVED SOLVENT CEMENT SHALL BE USED TO JOIN ALL DUCTS, FITTINGS AND BENDS AT MINIMUM 30 MINUTES PRIOR TO POURING CONCRETE.
- 2.3. ALL DUCTS AT THE FACE OF THE DUCT BANK SHALL BE ORIENTED AND TERMINATED WITH EITHER BELL ENDS SUPPORTING CABLES OR PLUGS FOR SPARE DUCTS
- 2.4. DUCTS SHALL BE SUPPORTED WITH APPROVED SPACERS EVERY 1.5 m (5 ft) AND BE ANCHORED SO AS NOT TO FLOAT DURING CONCRETE POURING.
- 2.5. ALL DUCT BANKS SHALL BE REINFORCED WITH NON PRE-STRESSED STEEL REINFORCING BARS - GRADE 400 AND CONFORMED WITH CSA G30.12 (LATEST REVISION). STEEL REINFORCING BARS SHALL BE INSTALLED CONTINUOUSLY, MINIMUM 300 mm OVERLAP AND TIED, AND BE LOCATED AT THE BOTTOM OF THE DUCT BANK
- 2.6. STEEL REINFORCING BARS SHALL BE EXTENDED BEYOND THE DUCT BANK FOR FUTURE DUCT BANK EXTENSION. REINFORCING BARS SHALL BE PASSED CONTINUOUSLY FROM ONE DUCT BANK TO THE OTHER.
- 2.7. DUCTS SHALL BE ENCASED IN 20MPa CONCRETE WITH 10 mm PEA GRAVEL AGGREGATE. SLUMP MUST NOT EXCEED 100 mm (4") UNDER STANDARD SLUMP TEST. EARTH UNDER DUCT BANK SHALL BE THOROUGHLY COMPACTED PRIOR TO DUCT BANK INSTALLATION TO ELIMINATE SETTLING OF FINISHED DUCT BANK.
- 2.8. ALL DUCTS SHALL BE MANDRELLED AND BE CLEANED AFTER DUCT BANK INSTALLATION.
- 2.9. ALL DUCTS SHALL BE EQUIPPED WITH 10 mm (3/8") DIAMETER POLYPROPYLENE ROPE. ALL DUCTS SHALL HAVE THE ENDS SEALED WITH AN APPROVED DUCT PLUG IMMEDIATELY AFTER DUCT BANK INSTALLATION
- 2.10. END OF DUCT BANK AND ROAD CROSSING SHALL BE MARKED WITH AN ELECTRONIC

3. CUSTOMER OBLIGATIONS

- 3.1. CUSTOMER'S DUCT BANK INSTALLATION SHALL BE SUBJECTED TO DISTRIBUTOR'S INSPECTION AND ACCEPTANCE PRIOR TO POURING OF CONCRETE OR ANY BACKFILL MATERIAL, OR WILL NOT BE PASSED. CUSTOMER SHALL CONTACT DISTRIBUTOR INSPECTION DEPARTMENT TO ARRANGE FOR INSPECTION 48 HOURS IN ADVANCE OF POURING CONCRETE
- 3.2. THE CUSTOMER SHALL FOLLOW DIRECTIONS GIVEN BY THE DISTRIBUTOR'S INSPECTOR FOR ANY SITUATION NOT COVERED IN THIS SPECIFICATION.
- 3.3. DUCTS SHALL BE PROBED PRIOR TO CABLE INSTALLATION. CABLE SHALL NOT BE INSTALLED IN DUCT WHICH DOES NOT ALLOW PASSAGE OF A TEST MANDREL SIZED TO 95 % OF THE DIAMETER OF THE PVC TYPE DB2/ES2 DUCT.
- 3.4. LANDSCAPING, PAVING AND CURBS SHALL NOT BE COMPLETED UNTIL DISTRIBUTOR'S CABLE INSTALLATION IS COMPLETE. OTHERWISE, ALL RESTORATION SHALL BE DONE BY THE CUSTOMER AT THEIR OWN EXPENSE.

FIGURE 2 SECONDARY SERVICE DUCT INSULATION 1-PHASE OR 3-PHASE SERVICES

1. WHENEVER POSSIBLE, THE RISER CABLES SHOULD BE LOCATED TO THE SIDE OF POLE OPPOSITE TO ON-COMING TRAFFIC (OESC BULLETIN DTB-06/06).
2. DUCT TO BE ENCASED IN CONCRETE IF MINIMUM DEPTH CAN NOT BE MET. SEE FIGURE 1 AND FIGURE 1A.

* ALL UNITS OF MEASUREMENT ARE IN MILLIMETERS UNLESS OTHERWISE STATED

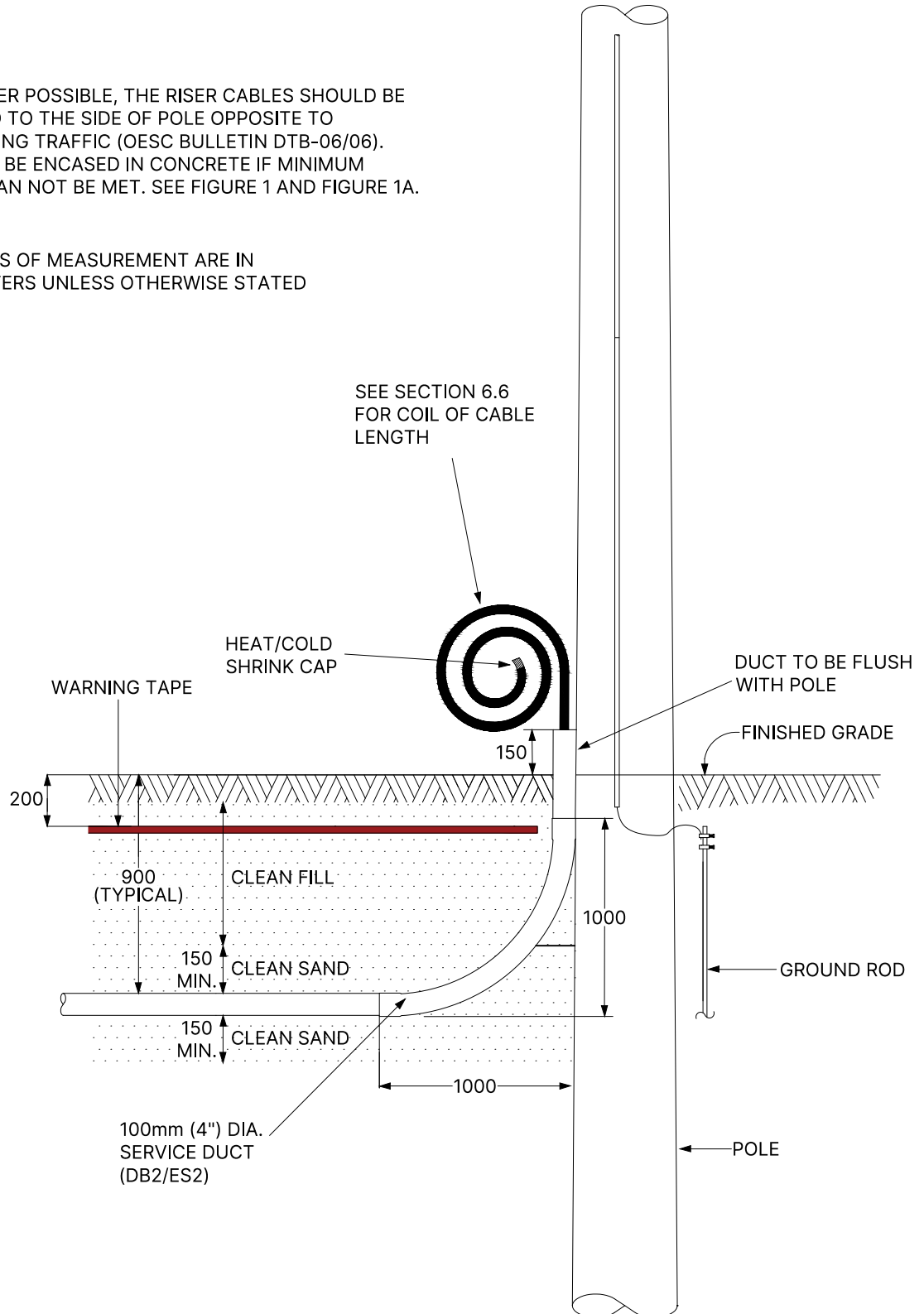
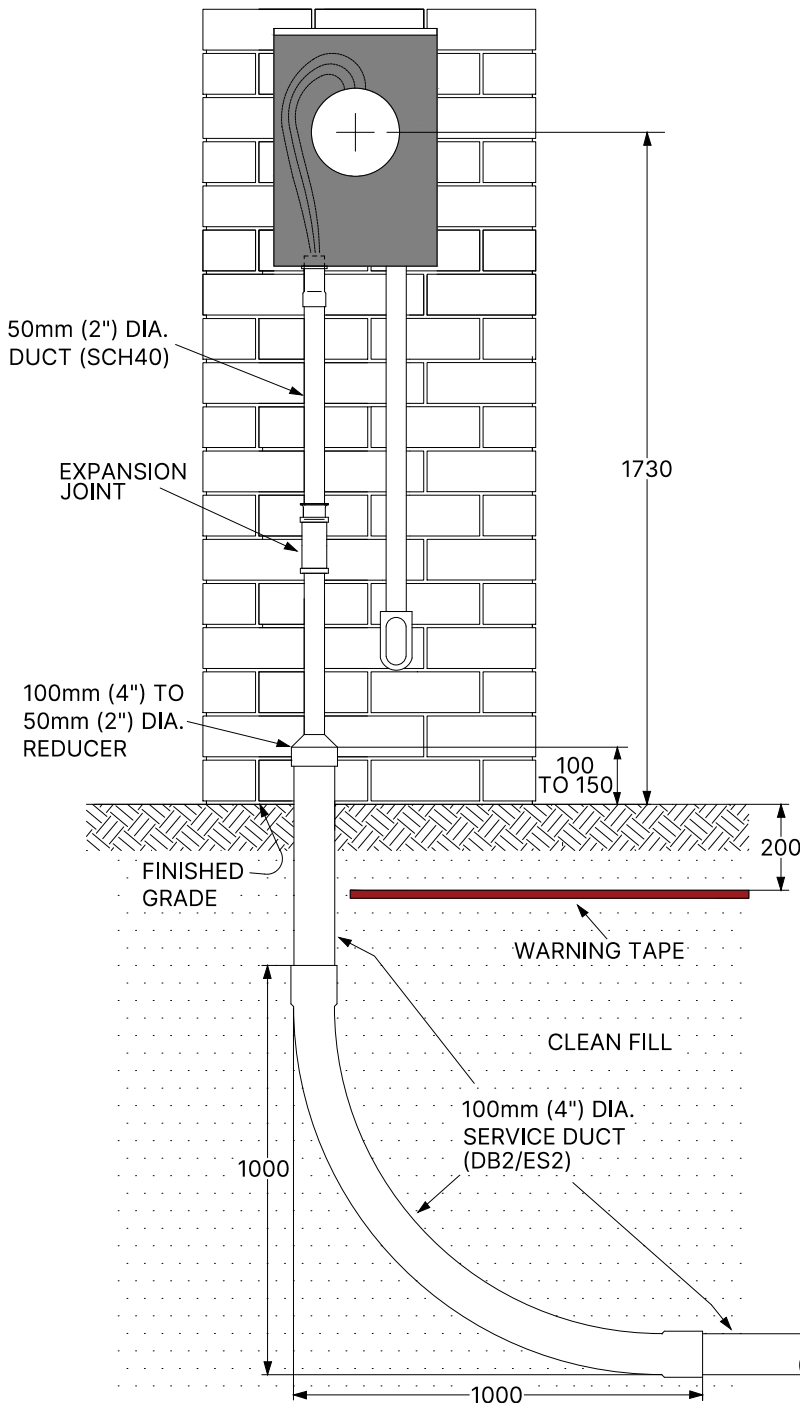

FIGURE 3 AND 4 UNDERGROUND SECONDARY SERVICE DUCT AND TYPICAL SERVICE TRENCH EXAMPLE

FIG 3

UNDERGROUND SECONDARY SERVICE DUCT



1. ALL UNDERGROUND CABLES ARE TO BE INSTALLED IN EITHER, I. 100mm TYPE DB2/ES2 PVC DUCT OR, II. SMOOTH-WALL SDR-13.5 HDPE DUCT
2. ALL DUCT TO BE INSTALLED WITH 150MM OF GRIT-FREE MASONRY MORTAR SAND ABOVE AND BELOW THE CONDUIT.
3. DUCT TO BE CONCRETE ENCASED IF REQUIRED. SEE FIGURE 1 AND FIGURE 1A.
4. SUPPLY AND INSTALL BURIED CABLE WARNING TAPE AT 200mm BELOW FINISHED GRADE SPANNING FULL LENGTH OF TRENCH
5. ALL 90 DEGREE BENDS IN CONDUIT TO BE A MINIMUM 1000mm RADIUS
6. SERVICE DUCT TO BE INSPECTED BY LAKELAND POWER BEFORE SERVICE TRENCH IS BACKFILLED

* ALL UNITS OF MEASUREMENT ARE IN MILLIMETERS UNLESS OTHERWISE STATED

FIG 4

TYPICAL SERVICE TRENCH SECTION

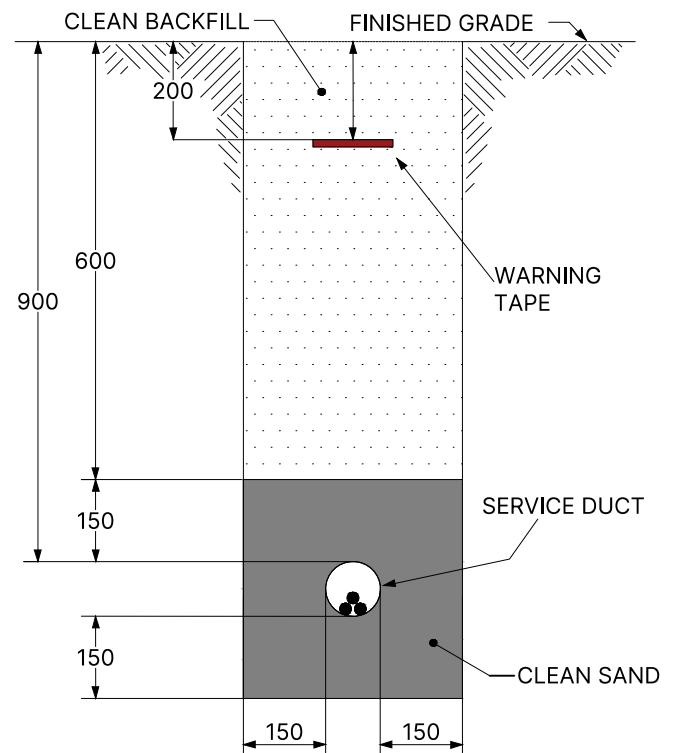

FIGURE 5 PADMOUNT EQUIPMENT FOUNDATION AND GROUND GRID

1. SEAL ALL WALL FOUNDATION PENETRATIONS TO REDUCE WATER INGRESS.
2. AT MINIMUM ONE OF THE GROUND LEADS ENTERING THE SUPPORT FOUNDATION MUST BE ONE CONTINUOUS PIECE OF WIRE CONNECTING TO ALL FOUR GROUND RODS.
3. GROUND LEADS MUST ENTER SUPPORT FOUNDATION OPPOSITE EACH OTHER.
4. SUPPORT FOUNDATION DIMENSIONS AS PER MANUFACTURER.
5. LOCATION OF SECOND CONNECTOR CAN BE ON THE GROUND ELECTRODE OR GROUND WIRE.
6. WHERE PRACTICABLE GROUND ELECTRODE SHALL BE BELOW FROST LINE.
7. GROUND ROD CONNECTOR SHALL BE RATED FOR BELOW GRADE CONNECTIONS.
8. FOR BELOW GRADE APPLICATIONS INSTALL CONCRETE LID AND PROVIDE 30 cm (12") MIN. OF GROUND COVER.
9. ALLOW FOR BACKFILL AND GROUNDING REQUIREMENTS AND CONSIDER USE OF CONDUCTIVE CEMENTIOUS AND/OR CARBONACEOUS MATERIAL TO ENHANCE GROUNDING.

* ALL UNITS OF MEASUREMENT ARE IN MILLIMETERS UNLESS OTHERWISE STATED

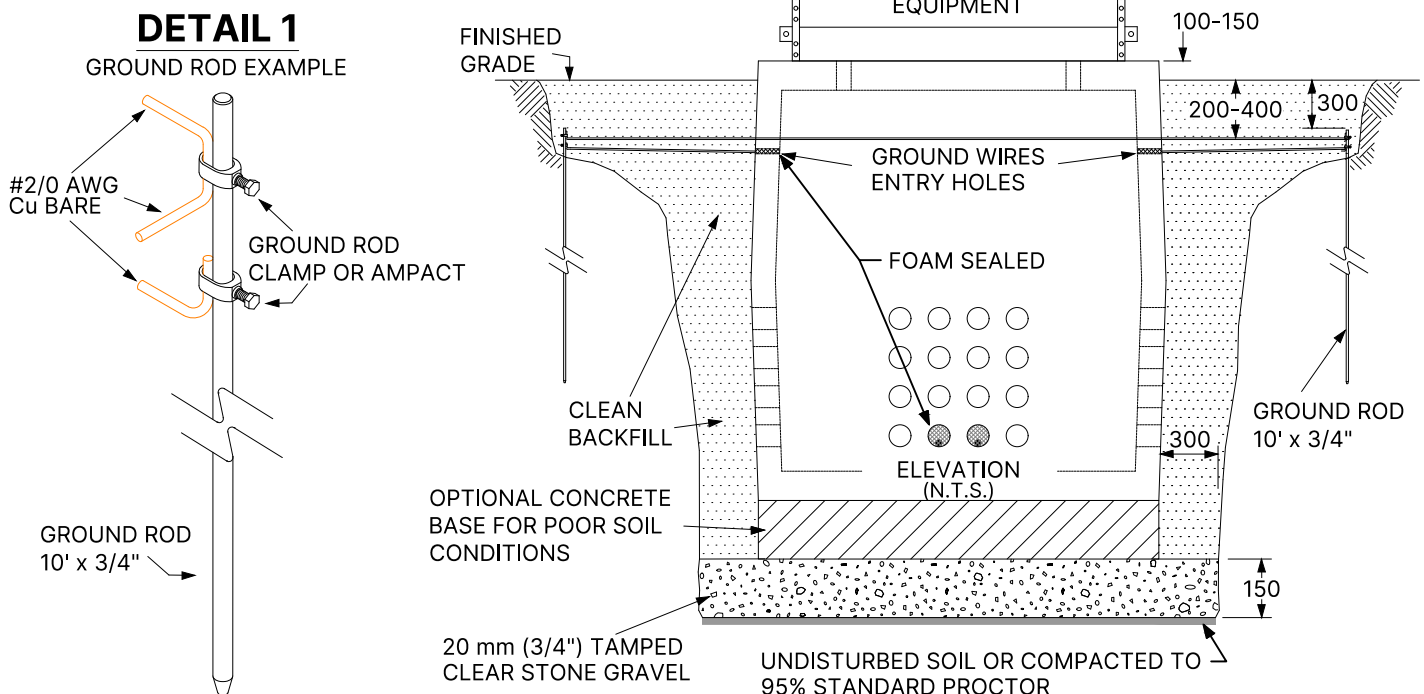
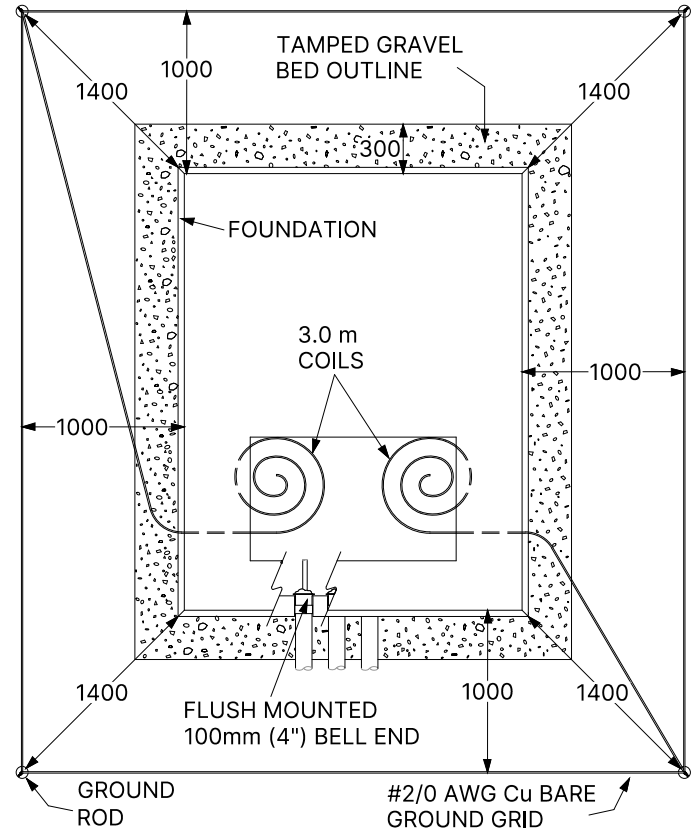
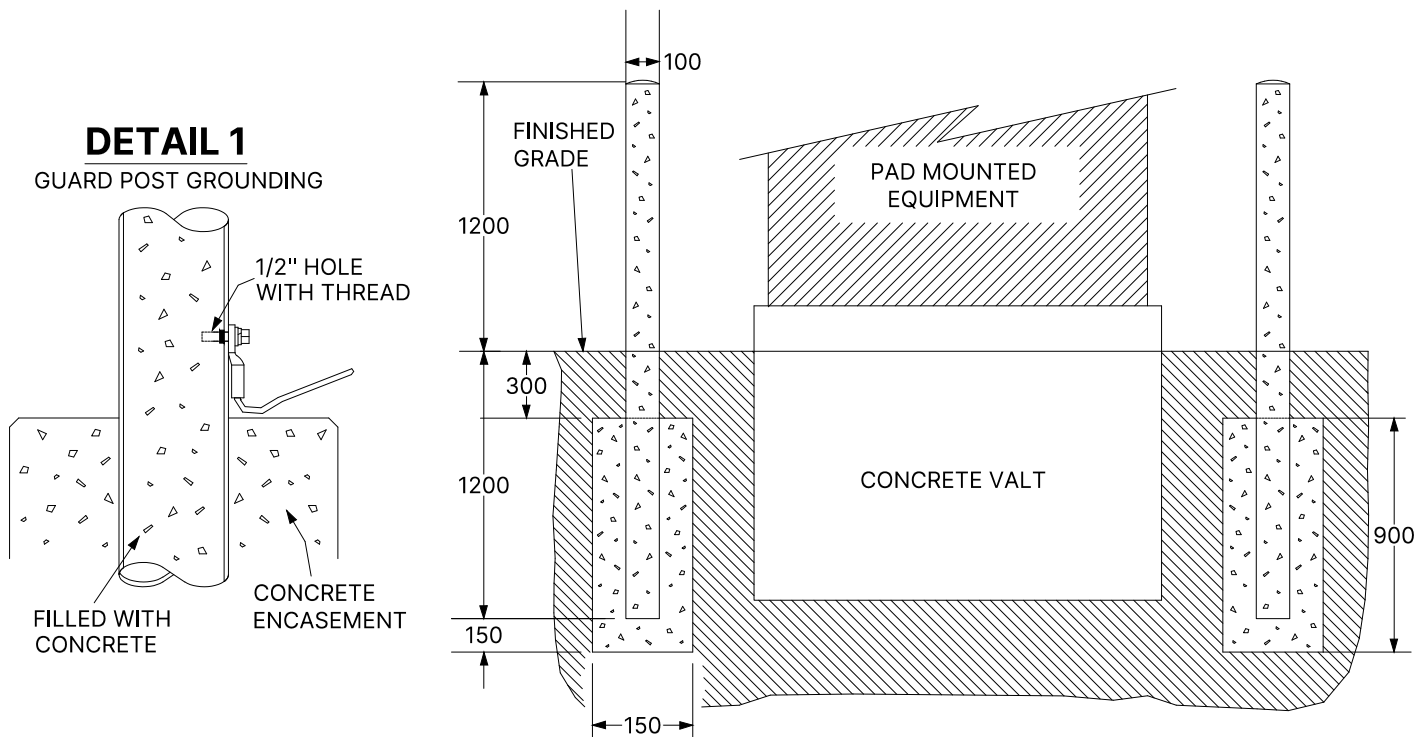

FIGURE 6

DETAIL FOR BOLLARD GUARD POST INSTALLATION AND GROUNDING



1. GUARD POST SHALL BE 100mm GALVANIZED STEEL OR PAINTED WITH RUST-RESISTANT PAINT. PLASTIC COVERS MAY BE INSTALLED.
2. DIMENSIONS EQUIPMENT GIVEN IN THIS FIGURE ARE TYPICAL. ACTUAL DIMENSIONS SHALL BE DETERMINED IN ACCORDANCE WITH THE SPECIFIC EQUIPMENT BEING INSTALLED.
3. EQUIPMENT IN HIGH-TRAFFIC AREA MIGHT REQUIRE ADDITIONAL GUARD POSTS ON THE PERIMETER.
4. GUARD POST LOCATIONS TO BE DETERMINED BASED ON THE DIRECTION OF POTENTIAL THREAT.
5. CARE SHOULD BE TAKEN TO ENSURE THAT THE GUARD POST DOES NOT HINDER THE OPERATION, MAINTENANCE, OR REPLACEMENT OF THE EQUIPMENT.
6. GUARD POST SHALL BE CONNECTED TO GROUND GRID (AS SHOWN) OR TO GROUND ROD AS SHOWN, OR WITH APPROVED CONNECTION.

* ALL UNITS OF MEASUREMENT ARE IN MILLIMETERS UNLESS OTHERWISE STATED

